

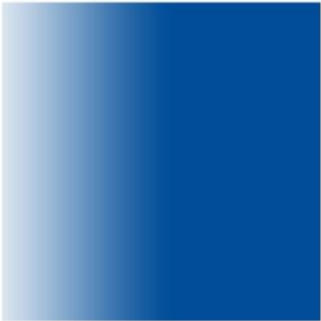

 **autocraft**

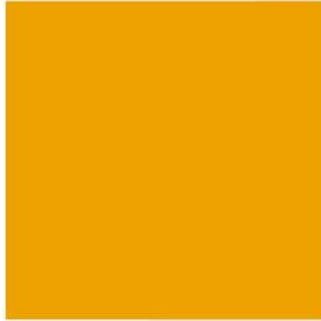

Shanghai Autocraft Co., Ltd.

World Class Fastener Manufacturer

20160406YCL-EU
simplified

www.autocraft-china.com

Company Profile



- Over 20 years' manufacturing experience, new facility set up in 2005 in expansion
- Total area 88000 m²
- Over 450 employees
- State-of-the-art world class manufacturing facilities with production processes including wire processing, cold heading, thread rolling, heat treatment, surface treatment, sorting and packaging
- Registered to ISO9001, TS16949, ISO14001 and OHSAS18001, ISO/IEC17025 accredited lab
- Manufactures standard and automotive fasteners
- Annual manufacture capacity approx.60,000 tons

Location



Pudong, Shanghai

Location: Nanhui, Pudong New Area, Shanghai

-- 25 Minutes to Pudong International Airport

-- 15 minutes to Shanghai Disney Land

Main Products and Markets - 1

1. Product categories: both standard and non-standard fasteners available:

-- Standard fasteners:

- 8.8/10.9/12.9 hex bolts and socket screws;
- tapping screws, chipboard and wood screws, washers and nuts;

-- Non-standard fasteners for OEM clients in automotive, truck and earth-moving equipment, etc. ;

2. Size Ranges:

- Bolts and Screws: M3-M30, length up to 350mm
- Nuts and Washers: M3-M30

3. Capacity: 5000 tons/month

Analysis of Our Capacity:

1) Total is 5000 tons per month, among which:

50% for OEM or automotive fasteners = 2500 tons per month

50% for standard fasteners = 2500 tons per month, and among which

Approx. 60% of standard fasteners is high tensile class 10.9+12.9 = 1500 tons;

Approx. 40% of standard fasteners is class 8.8 and others screws = 1000 tons

2) summary: capacity 1000 tons for standard 8.8 bolts and screws, 1500 tons for 10.9+12.9 bolts, and 2500 tons automotive fasteners.



Main Products and Markets - 2

A complete fastening solution

automotive
fasteners &
special parts



high-end
industrial
fasteners

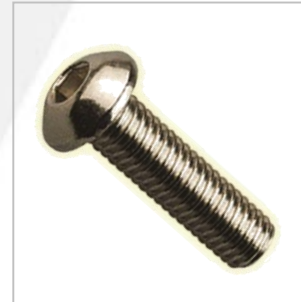

Commercial
fasteners



High-end industrial fasteners

High tensile class 8.8/10.9/12.9, grade 5/8

| Picture | Product | Specification | |
|--|------------------------------|--|---|
|  | Hex socket head cap screw | DIN 912, ISO 4762, JIS B 1176 Class 8.8/10.9/12.9 M3 - M30 | ANSI / ASME B18.3 Alloy steel 6# - 1 1/4 |
|  | Hex socket button head screw | ISO 7380, JIS B 1174 Class 8.8/10.9/12.9 M3 - M16 | ANSI / ASME B18.3 Alloy steel 6# - 5/8 |
|  | Hex socket flat head screw | DIN 7991, ISO 10642, JIS B 1194 Class 8.8/10.9/12.9 M3 - M16 | ANSI / ASME B18.3 Alloy steel 6# - 5/8 |
|  | Hex head cap screw | DIN 931, 933, 960, 961, ISO4014 4017, Class 8.8/10.9/12.9 M6 - M30 | ANSI / ASME B18.2.1 Grade 5/8 1/4 – 1 1/4 |



Durasok®

Durahex®



Branded Product: DURASOK – Advanced Socket Screw Technology

Durasok socket screws are advanced in design and manufacture technology which make them high-performance. They are very well used in industries like aviation, automotive, high speed train, military, heavy equipment, etc.

High performance leads to reduced number of screws used for the same joint, smaller and lighter equipment, less machine failure and down time. Durasok means extra benefit at less cost.

Durasok socket screws are available in China through Autocraft, providing top-grade solution for customers who demand maximum precision, service life, reliability and premium technical services.

Excellent design and performance

- 1 Higher level of mechanical properties
- 2 Smooth wide radius at the root of the runout and complete threads render Durasok stronger and more fatigue resistant than regular flat or sharp root thread screws.
- 3 Specially designed fillet radius increases screw fatigue life by 100% at critical head shank juncture
- 4 Optimized tooling and forging technology drive metal to flow evenly and continually without laps, ending Durasok with excellent properties
- 5 Patented marking of thread size in the head facilitates the identification of the screw size
- 6 Tight tolerance and well controlled depth of the socket engage the wrench to the best making proper seating of the screw easier



Reliable process and service

- Advanced quality management system — ISO9001, TS16949 and AS9100 certified; lean manufacture practiced
- Computerized annealing, heat treat and finish process for quality uniformity
- Latest and state-of-the-art raw material spheroidizing annealing process to avoid oxidation and decarburization of wire
- Latest coating technology to ensure long period of protection against corrosion
- Special technical training and support for distributors and customers
- Strict production and dispatching record kept for total traceability solution
- Complete product range with national distribution network

Please visit our web site to learn more:

www.autocraft-china.com

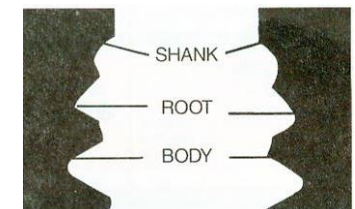
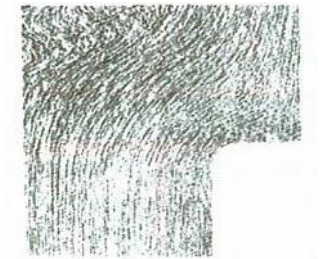

Manufactured by Autocraft Industrial (Shanghai) Ltd. in collaboration with Autocraft USA, LLC

Commercial Fasteners -- *Construction Screws*

- **Twin thread / twin fast wood screws**
- **Chipboard screws,**
- **Drywall screws, Decking screws**
- **Self-drilling screws,**
According to DIN/EN or drawing

Size: Ø3.0-Ø12.0, length up to 450 mm

Finishes available:

- Zinc plated Yellow Cr6+,
- Zinc plated Cr3+,
- Ruspert 1000-2000 hrs NSST,
- Grey Phosphate oiled or waxed
- Black Phosphate oiled or waxed

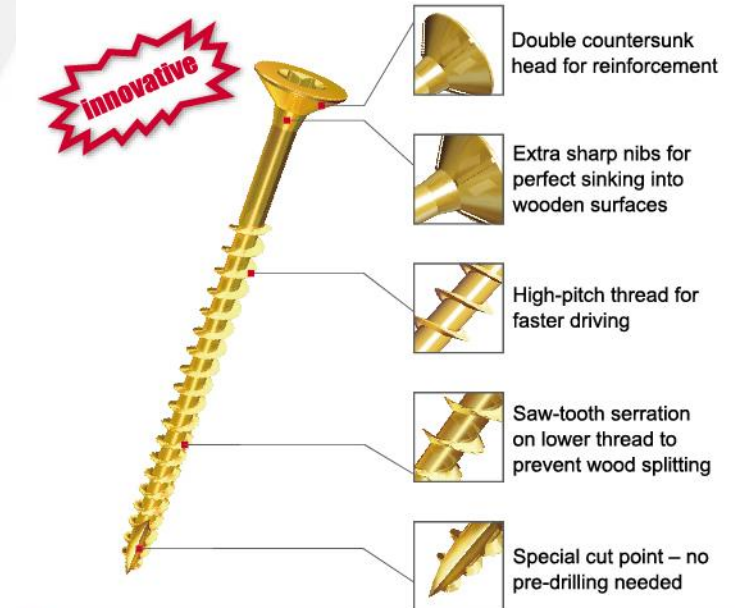

OEM PARTS -- Chassis & Body Fasteners

For Volvo, Ford, GM, VW, Changan, JAC etc.



Hex lobe recess button head with washer screw



Pan head six lobe socket Taptite screw

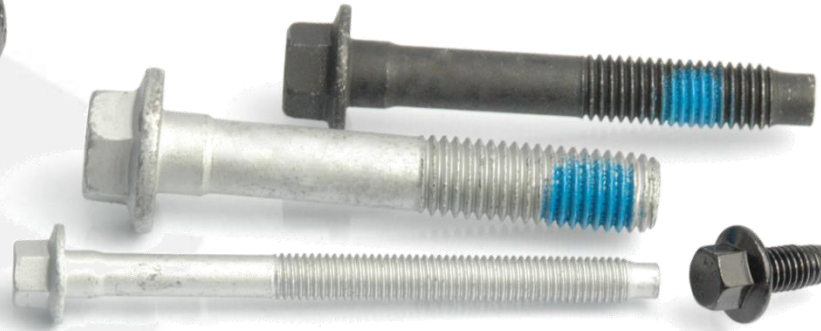

Hex flange bolt

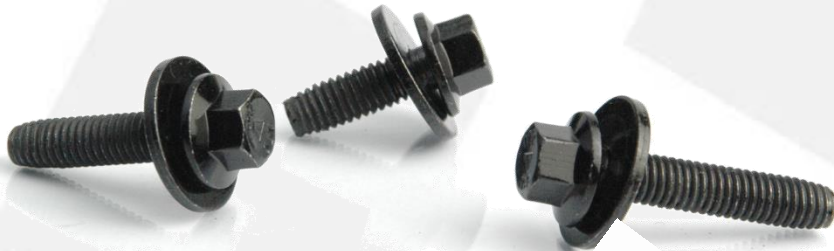

Taptite thread rolling screw with washer



Pan lobed socket shoulder Duo-Taptite screw



Weld screw



Wheel stud

OEM PARTS -- Engine Fasteners

Engine bolts for FIAT, MAN, CUMMINGS, CAT, JEELY, CHANGAN ETC.

Flywheel case bolt

Main bearing bolt

Cylinder head bolt

Connecting rod bolt

Cylinder head main bolt

Other bolts



Flywheel bolt



Cylinder head main bolt

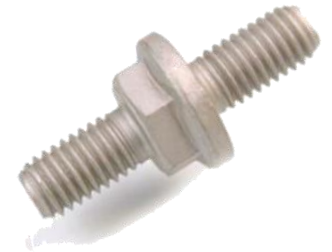

Double end stud



Cylinder head bolt



Con rod bolt



Spline soc flange screw

OEM Fasteners for off-high-way vehicles

For CAT, John Deere etc.



OEM Fasteners for Earth Moving Equipments

Crawler track shoe and sprocket fasteners



Socket head cap screw



Sprocket fixing bolt
Hex cap screw



Track shoe bolt/nut



Fixing bolt
Hex cap screw

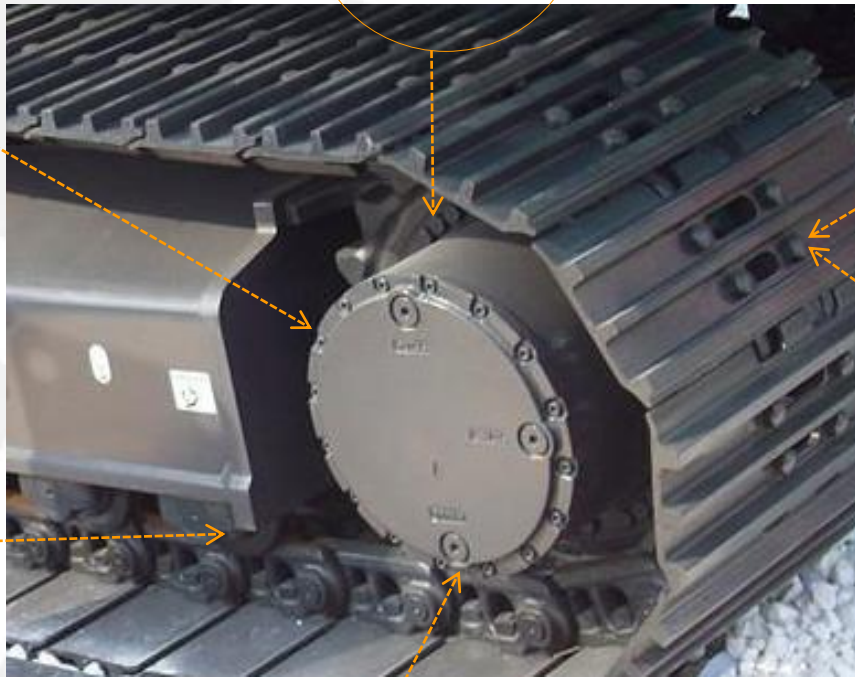

Track shoe bolt



Socket flat head cap screw

Nuts, Female parts and Stamped parts

for OEM's and distributors



Wheel nuts



Square weld nuts



Output shaft locking parts



Projection weld nuts

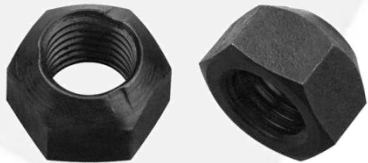

All metal lock nuts



Rivet nuts



Nut washer assembly



Washers and stamped parts

Special Coating Technologies

Autocraft can supply products with a wide range of specialized coatings with top coats and patches:

- Nylok
- Three Bond
- Loctite
- 3M Scotch-Grip
- Precoate

- Dacromet
- Geomet
- Magni
- Delta



Manufacturing Process

Major process: Raw material processing → Heading → Thread rolling → Heat treat → Surface treat → Automated sorting → Packing

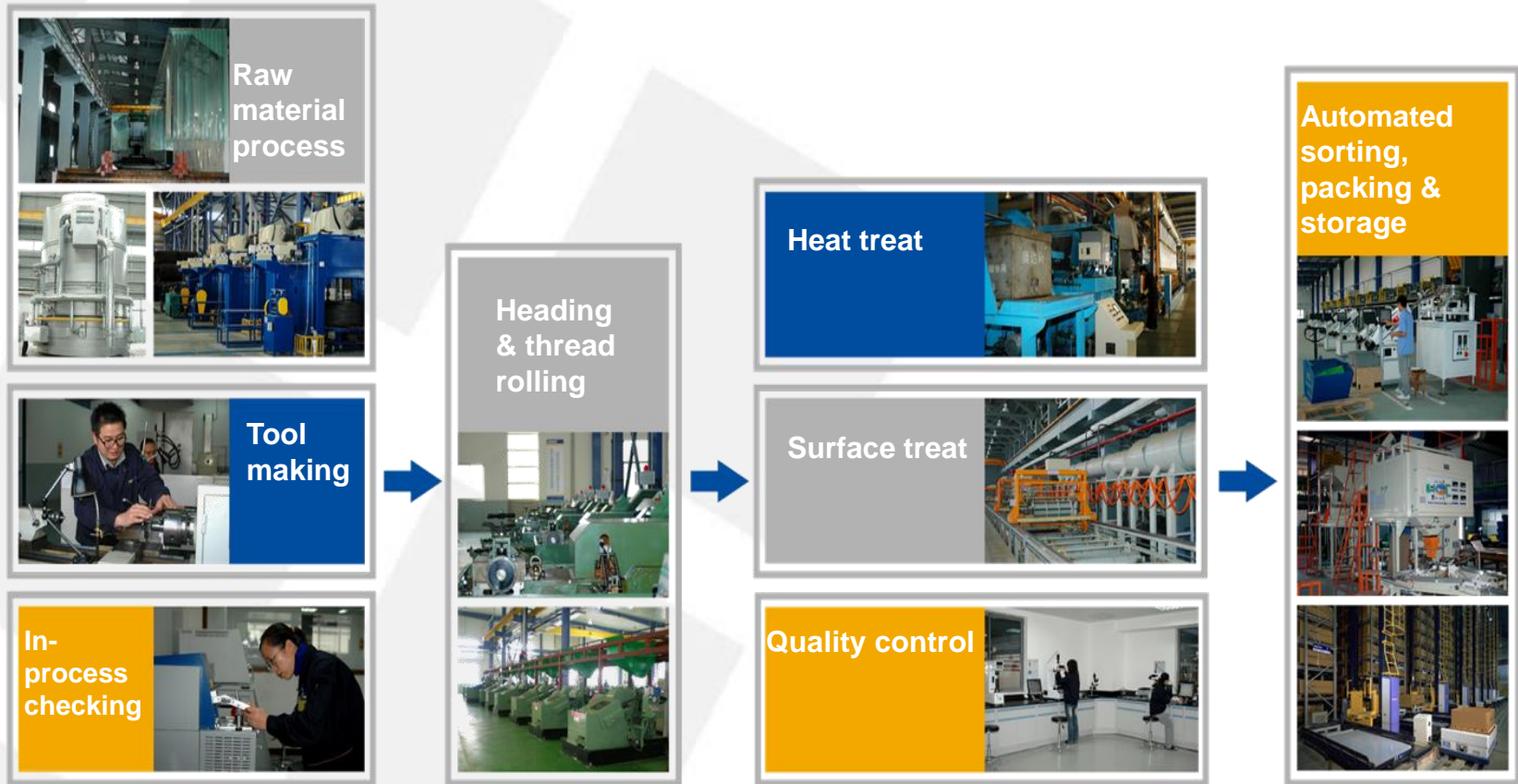

Wire Processing

- **Bell type annealing furnaces**
(world best in the industry)



- **Wire drawing machines**



Cold Heading

- **Multi-station Cold Formers**
imported from USA and Korea
--high precision and efficiency
- **Bolt formers with wide range**
for M3 - M33mm
max part length 350mm
- **6 station nut part formers**
for nuts and female parts
with internal and/or external thread



Thread Rolling

Flat die thread rolling machines from Taiwan ▶

Round die thread rolling machines from Taiwan ▶

Thread tapping machines ▶



Heat Treatment

- **Continuous mesh belt furnace**
Fully computerized and automated

- **De-phosphating line**



Surface Treatment

- **Phosphating line,
acid zinc plating line, alkaline
zinc/zinc nickel plating line**

PLC control and fully automated

Trivalent

Chemicals approved by OEMs

- **Hydrogen De-embrittlement
-- continuous line and batch
furnaces**



Sorting Machines



- Automated Sorters with Laser, Eddy Current, and Vision from USA

- Roller Sorting

capable of sorting for:
dimensional problems,
thread defects,
foreign parts & cracks

Automated Warehouse

Wholly automated

Barcode system



Research & Development

R&D and Application Engineering by our fastener experts

- Technical research in basic fastener theory, manufacturing, assembling, and testing, etc.
- Research in forming tool design and making
- Synchronized design & development with OEMs
- Assembling support and failure analysis
- Fastener technology exchange

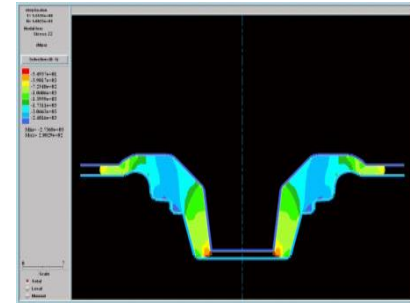

Licensed technology –Taptite 2000 & Taptite II License

We are a licensed Taptite2000 and Taptite II manufacturer. We produce these products for Changan Ford, Volvo and VW.

This license allows Autocraft to manufacture and supply genuine products listed below:

TAPTITE®
TAPTITE® II
DUO-TAPTITE®
TAPTITE 2000®
MAGTITE 2000®
EXTRUDE-TITE®
FASTITE® 2000™

PLASTITE®
PUSHTITE II®
POWERLOK®
KLEERLOK®
SEAL PRODUCTS
B-, C-, P-, S-TITE®

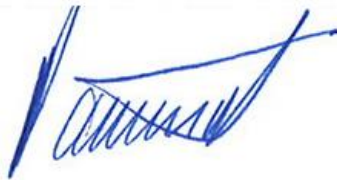

Peter Kammüller
Director Market Development

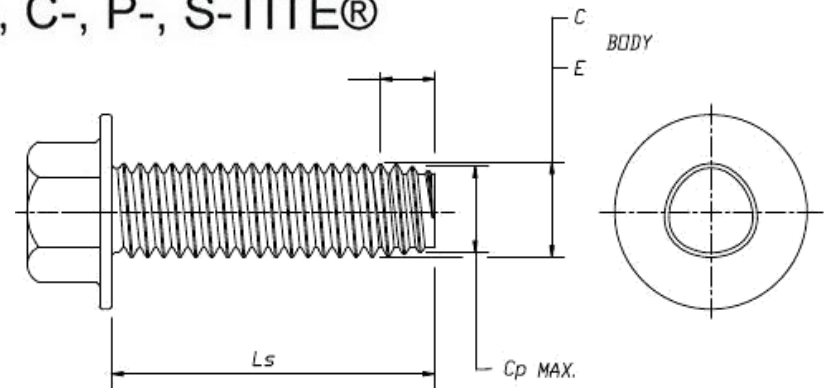

Licensed technology – Remform License

We are a licensee of Remform tapping screws for plastic components.

Mr. Cunlu Yan
Shanghai Autocraft Co. Ltd.
168 Nanlu Highway
Nanhui Industrial Zone
Shanghai 201300
China

15th November 2010

Dear Mr. Yan

Please find enclosed one original copy of the above mentioned agreement (REMFORM®) and amendment3 (TRILOBULAR®) for your safekeeping.

Kind regards

Sylvia Perotto

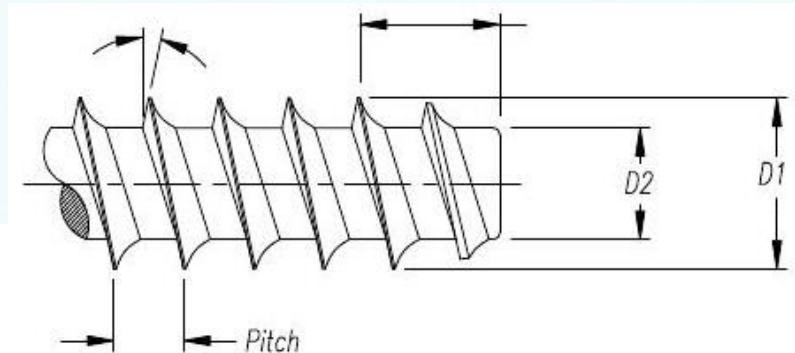

Licensed technology – MAThread and MATpoint

We are a licensee of MAThread and MATpoint. We supply GM.

This letter confirms that Autocraft Industrial (Shanghai) Ltd., located at No. 168 Nanlu Highway, Nanhui Industrial Zone, Shanghai, China is a MAThread, Incorporated licensee in good standing. They are licensed to quote, manufacture, and market MAThread® and MATpoint® products worldwide.

Please contact me with any questions or concerns.

Sincerely,



Judy W. Spicer
Director of Business Operations

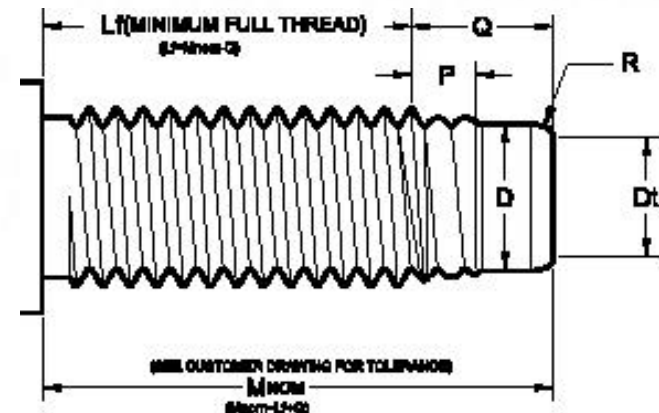

Quality Assurance

- Certified to ISO/TS16949
- Set up effective quality management system per ISO/TS16949
- Deployment of 5 manuals: APQP, FMEA, SPC, MSA & PPAP
- Lab accredited to ISO/IEC17025
- Lean Six Sigma production system

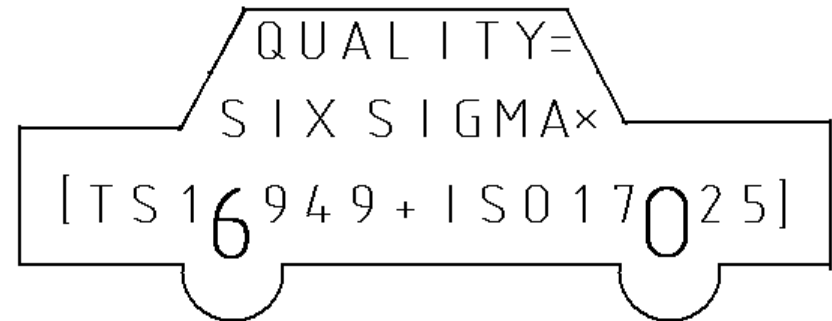

Management System Certificates

ISO/TS 16949



ISO 9001



ISO/IEC17025



ISO 14001



OHSAS 18001



Quality Inspection Flow

IQC – incoming QC
IPQC – in-process QC
FQC – final QC

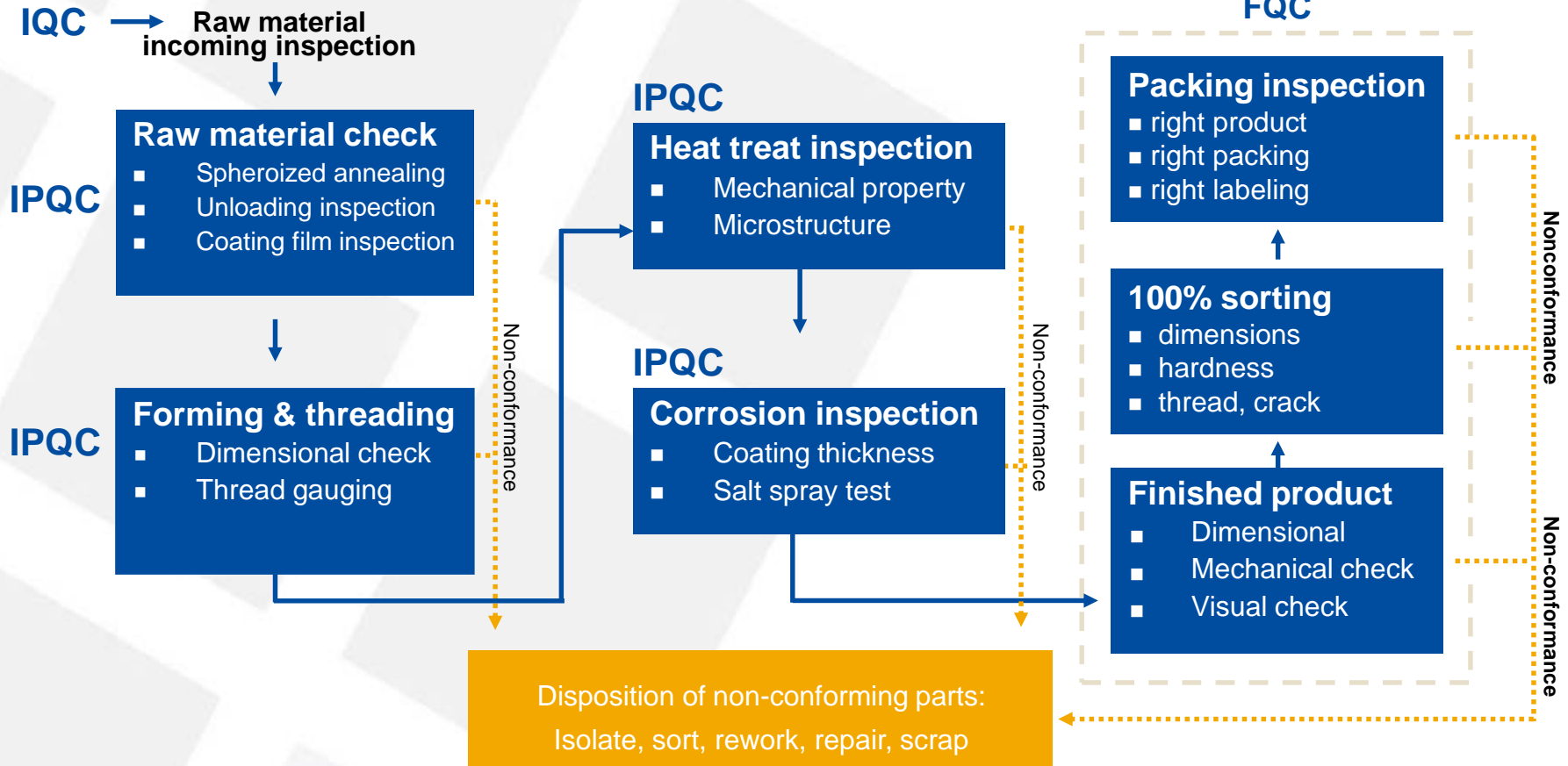

Advanced Testing Center

Our central lab is certified as per ISO17025

Scope of testing facilities:

- Chemical composition
- Hardness test
- Metallographic structure
- Tensile
- Fatigue strength & life
- Impact toughness
- Torque, tension & friction
- Driving speed
- Contour measurement
- 3D dimension measurement
- Coating thickness & salt spray life
- Magnetic particle & eddy current test
- Sorting (laser, eddy current, vision, roller)

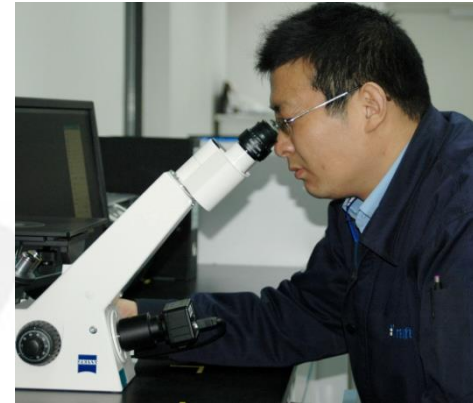

Test Facilities -1



Vacuum spectrometer from Germany



Japanese FUTURETECH hardness tester

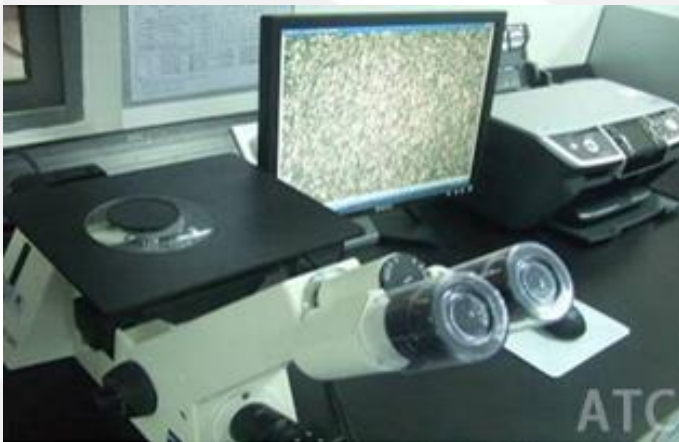

Metallographic microscope from Germany



Contour-graph from Germany

Test Facilities -2



Dimensional laser lab from USA



US MTS-SANS tensile tester



Swiss made high frequency fatigue tester



Impact toughness tester

Test Facilities -3



Torque-tension-friction tester from Germany



German X-Ray coating/plating film tester



Magnetic particle flaw detector



Salt Spray Test Chamber

Global Presence

International Team Serving customers all over the world



Shanghai Autocraft Co., Ltd.
168 Nanlu Highway, Pudong
Shanghai 201300 - China
Tel: +86 21 3818 1068
Fax: +86 21 3818 1199
E-mail: info@autocraft-china.com
[www: autocraft-china.com](http://www.autocraft-china.com)



The Autocraft advantages

Cost saving and superior service with Autocraft

International standards



Raw material processing



Complete processes



Automated production



Full product range



Customized production



Total quality control



Innovative services



Superior supply chain



AUTOCRAFT -- World's Leading Fastener Manufacturer

Thank You

Shanghai Autocraft Co., Ltd.
168 Nanlu Highway, Pudong New Area
Shanghai 201300 - China
Tel: +86 21 3818 1068
Fax: +86 21 3818 1199
E-mail: info@autocraft-china.com
www: autocraft-china.com

