



BobTail®
Next step in
LockBolt Evolution



BobTail® Next step in LockBolt Evolution

The Huck BobTail system includes LockBolts and installation tooling that will deliver you benefits beyond anything that Alcoa Fastening Systems Industrial Division has produced before.



Key Benefits:

Cycle Installation Speed

Speed of fastener installation has to be seen to be believed with the 1/4 diameter BobTail fastener installing in less than 1 second. The 16mm diameter BobTail fastener installs in 2 seconds, up to twice as fast as any large diameter LockBolt on the market.

To see installation video visit www.afshuck.net

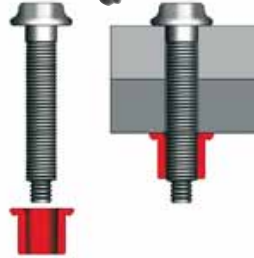

No pin-tail or pin-break

- No material waste
- Low installation noise
- Increased corrosion resistance

Smooth, shock free installation sequence

Eliminates jolts to the operator's arms and hands

Unique helical lock groove (12mm diameter upwards)

Holds pin and collar in place prior to installation

High Fatigue Strength Thread Form

Shallow thread and large root radius increase fatigue strength



Hardened Pin

Softer collar material flows between lock-grooves

Installation indicator on collar for visual inspection (12mm diameter upwards)

The swage indicators indent when installation is complete



Prior to Installation



After Installation

Combined with all the benefits of using a Huck LockBolt

- Permanent, mechanically locked fastener:
 - Installation process automatically provides fastener values
 - No torque or re-torque required
- Unlike conventional nuts and bolts, they will not work loose, even during extreme vibration
- Easy visual inspection ensures correct installation

Convert from other Huck LockBolts to BobTail

If you are currently using Huck C50L or C6L Lockbolts then due to the dimensional and strength similarities it is quick and easy to switch BobTail to gain the extra benefits listed above*.

Consistent Clamp with BobTail

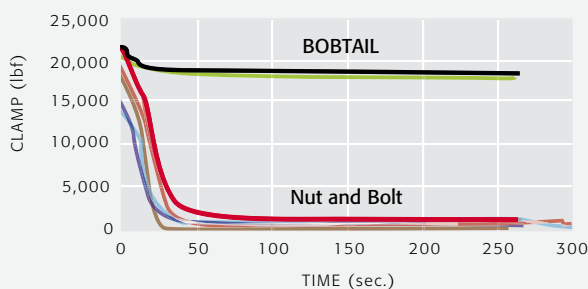

This chart shows nut and bolt clamp scatter is much wider compared to Bobtail, and that once vibration begins, clamp load quickly decays with conventional nuts and bolts, while it holds constant with the Bobtail.

* Some installation tooling adaptation will be needed.

Small Diameter BobTail

Uninstalled Dimensions

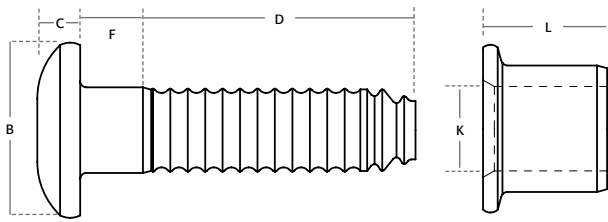

Head Style: Round, Truss Head

Material: Carbon Steel

Other head styles and materials available on request.

Grip range and Length table

Grip Number	Grip Range		4,8mm (3/16")	4,8mm (3/16")	6,4mm (1/4")	6,4mm (1/4")	7,9mm (5/16")	7,9mm (5/16")	9,5mm (3/8")	9,5mm (3/8")
	From (mm)	to (mm)	D Max (mm)	F Nominal (mm)	D Max (mm)	F Nominal (mm)	D Max (mm)	F Nominal (mm)	D Max (mm)	F Nominal (mm)
1	0,0	4,7			20,7	1,0				
2	0,0	6,4			22,2	1,6				
3	1,6	7,9			23,8	3,2				
4	3,2	9,5	21,2	3,2	25,4	4,7	29,4	4,7	33,3	4,8
5	4,7	11,1			27,0	6,4				
6	6,4	12,7	24,4	6,4	28,6	7,9	32,5	7,9	36,5	7,9
8	9,5	15,9	27,6	9,5	30,2	11,1	35,7	11,1	39,6	11,1
10	12,7	19,1	30,7	12,7	31,8	14,3	38,9	14,3	42,8	14,3
12	15,9	22,2	33,9	15,9	33,3	17,4	42,1	17,4	46,0	17,5
14	19,1	25,4	37,1	19,1	34,9	20,6	45,2	20,6	49,1	20,6
16	22,2	28,6	40,3	22,2	36,5	23,8	48,4	23,8	52,3	23,8
18	25,4	31,8	43,4	25,4	38,1	27,0	51,6	27,0	55,5	27,0
20	28,6	34,9	46,6	28,6	39,7	30,1	54,8	30,1	58,7	30,2

Head and Collar Dimension Table

Diameter (mm)	Head Dimensions		Collar Dimensions	
	B Max (mm)	C Max (mm)	K Max (mm)	L Max (mm)
4,8mm (3/16")	9,9	3,2	9,9	7,2
6,4mm (1/4")	13,6	3,6	13,1	9,7
7,9mm (5/16")	17,3	4,4	16,3	12,1
9,5mm (3/8")	20,83	5,3	19,56	14,35

Installed Dimensions

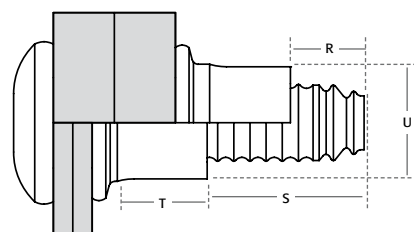

Installed Information and Max Hole Table

Diameter (mm)	Class 5.8			Class 8.8			Installed Dimensions				Max Hole (mm)
	Clamp (kN)	Tensile (kN)	Shear (kN)	Clamp (kN)	Tensile (kN)	Shear (kN)	R Min (mm)	S Max (mm)	T Min (mm)	U Max (mm)	
4,8mm (3/16")	4,6	7,3	7,7	5,3	9,8	10,8	3,9	11,7	5,0	6,9	5,6
6,4mm (1/4")	8,0	13,3	13,6	10,2	16,5	19,1	5,7	13,6	6,6	9,2	7,1
7,9mm (5/16")	12,5	20,5	21,0	18,7	26,7	29,8	7,1	15,2	8,3	11,6	9,1
9,5mm (3/8")	17,9	28,9	30,4	26,6	41,4	42,7	8,8	16,9	9,9	13,8	10,7

Metric Large Diameter BobTail

Uninstalled Dimensions

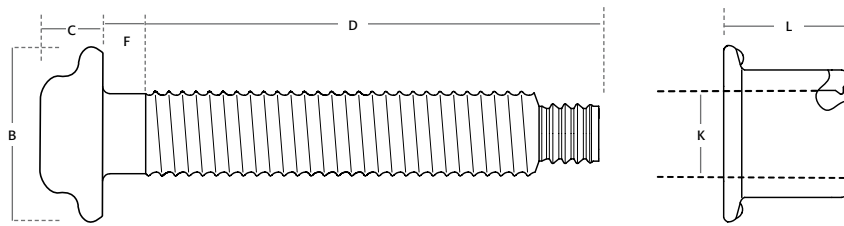

Head Style: Flanged

Material: Carbon Steel

Other head styles and materials available on request.

Grip range and Length table

Grip Number	Grip range		12mm	12mm	14mm	14mm	16mm	16mm	20mm	20mm
	From (mm)	to (mm)	D Max (mm)	F Nominal (mm)	D Max (mm)	F Nominal (mm)	D Max (mm)	F Nominal (mm)	D Max (mm)	F Nominal (mm)
10	5	15	46,1	3,8	49	3,8	52	3,8	60,7	3,8
15	10	20	51,1	3,8	54	3,8	57	3,8	65,7	3,8
20	15	25	56,1	3,8	59	3,8	62	3,8	70,7	3,8
25	20	30	61,1	3,8	64	3,8	67	3,8	75,7	3,8
30	25	35	66,1	3,8	69	3,8	72	3,8	80,7	3,8
35	30	40	71,1	3,8	74	3,8	77	3,8	85,7	3,8
40	35	45	76,1	3,8	79	3,8	82	3,8	90,7	3,8
45	40	50	81,1	3,8	84	3,8	87	3,8	95,7	3,8
50	45	55	86,1	3,8	89	3,8	92	9,5	100,7	3,8
55	50	60	91,1	3,8	94	3,8	97	9,5	105,7	3,8
60	55	65	96,1	3,8	99	3,8	102	9,5	110,7	3,8
65	60	70	101,1	3,8	104	3,8	107	9,5	115,7	9,5
70	65	75	106,1	3,8	109	3,8	112	9,5	120,7	9,5
75	70	80	111,1	3,8	114	9,5	117	9,5	125,7	9,5
80	75	85	116,1	9,5	119	9,5	122	9,5	130,7	9,5

Head and Collar Dimension Table

Diameter (mm)	Head Dimensions		Collar Dimensions	
	B Max (mm)	C Max (mm)	K Max (mm)	L Max (mm)
12mm	25,4	9,6	12,3	17,9
14mm	30	11,5	14,4	21,5
16mm	33,8	12,2	16,4	23,7
20mm	42,4	16	20,5	29,6

Installed Dimensions

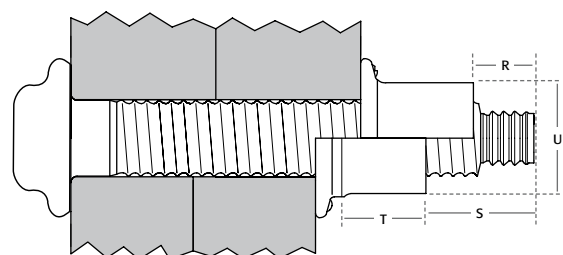

Installed Information and Max Hole Table

Diameter (mm)	Minimum Installed Strength Values			Installed Dimensions				Max Hole (mm)
	Clamp (kN)	Tensile (kN)	Shear (kN)	R Min (mm)	S Max (mm)	T Min (mm)	U Max (mm)	
12mm	64,9	87,7	65,4	11,1	23,7	13,1	17,3	13,5
14mm	87	120	94	11,2	24,6	15,5	20,2	15,5
16mm	116	163	122	11,2	23,3	17,4	23,1	17,5
20mm	181	255	191	14	26,7	21,8	28,8	22

Imperial Large Diameter BobTail

Uninstalled Dimensions

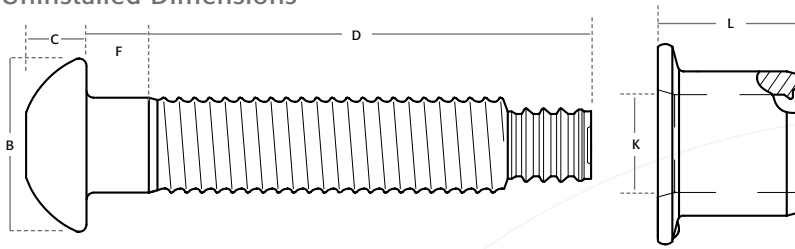

Head Style: Round

Material: Carbon Steel

Other head styles and materials available on request.

Grip range and Length table

Grip Number	Grip Range		12,7mm (1/2")		15,9mm (5/8")		19,1mm (3/4")		22,2mm (7/8")		25,4mm (1")	
	From (mm)	to (mm)	D Max (mm)	F Nominal (mm)	D Max (mm)	F Nominal (mm)	D Max (mm)	F Nominal (mm)	D Max (mm)	F Nominal (mm)	D Max (mm)	F Nominal (mm)
4	6,4	15,7	48,3	3,8	52,6	3,8	61,8	4,1	68,7	6,4	76,2	6,4
8	12,7	22,1	54,6	3,8	58,9	3,8	68,1	4,1	75,1	6,4	82,6	6,4
12	19,1	28,4	61,0	3,8	65,3	3,8	74,5	4,1	81,4	6,4	88,9	6,4
16	25,4	34,8	67,3	3,8	71,6	3,8	80,8	4,1	87,8	6,4	95,3	6,4
20	31,8	41,1	73,7	3,8	78,0	3,8	87,2	4,1	94,1	6,4	101,6	6,4
24	38,1	47,5	80,0	3,8	84,3	3,8	93,5	4,1	100,5	6,4	108,0	6,4
28	44,5	53,8	86,4	3,8	90,7	3,8	99,9	4,1	106,8	6,4	114,3	6,4
32	50,8	60,2	92,7	3,8	97,0	3,8	106,2	4,1	113,2	12,7	120,7	12,7
36	57,2	66,5	99,1	3,8	103,4	3,8	112,6	4,1	119,5	12,7	127,0	12,7
40	63,5	72,9	105,4	3,8	109,7	3,8	118,9	9,5	125,9	12,7	133,4	12,7
44	69,9	79,2	111,8	3,8	116,1	9,5	125,3	9,5	132,2	12,7	139,7	12,7
48	76,2	85,6	118,1	9,5	122,4	9,5	131,6	9,5	138,6	12,7	146,1	12,7
52	82,6	91,9	124,5	9,5			138,0	9,5	144,9	12,7	152,4	12,7
56	88,9	98,3	130,8	9,5			144,3	9,5	151,3	12,7	158,8	12,7
60	95,3	104,6	137,2	9,5			150,7	9,5	157,6	12,7	165,1	12,7
64	101,6	111,0					157,0	9,5	164,0	12,7	171,5	12,7
68	108,0	117,3					163,4	9,5	170,3	12,7	177,8	12,7
72	114,3	123,7					169,7	9,5	176,7	12,7	184,2	12,7

Head and Collar Dimension Table

Diameter (mm)	Head Dimensions		Collar Dimensions	
	B Max (mm)	C Max (mm)	K Max (mm)	L Max (mm)
12,7mm (1/2")	24,2	8,5	13,2	19,0
15,9mm (5/8")	30,4	11,0	16,4	23,7
19,1mm (3/4")	36,6	13,5	19,7	28,3
22,2mm (7/8")	42,3	14,9	22,9	33,0
25,4 (1")	50,8	16,5	26,2	37,8

Installed Dimensions

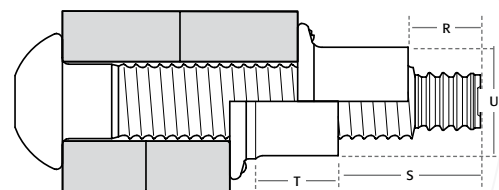

Installed Information and Max Hole Table

Diameter (mm)	Minimum Installed Strength Values			Installed Dimensions				Max Hole (mm)
	Clamp (kN)	Tensile (kN)	Shear (kN)	R Min (mm)	S Max (mm)	T Min (mm)	U Max (mm)	
12,7mm (1/2")	53,6	75,8	62,3	10,9	23,7	14,4	18,4	14,3
15,9mm (5/8")	85,4	120,5	100,1	10,9	24,4	18	23,1	17,5
19,1mm (3/4")	126,3	178,4	144,1	13,6	27,9	21,6	27,7	20,6
22,2mm (7/8")	174,6	246,7	193,1	15,2	30,3	25,1	32	23,8
25,4 (1")	229,1	323,4	251,3	17,4	33,2	29,2	36,9	28,6

Part Number Construction

Follow the form below to construct a part number for ordering BobTail pins and collars. Refer to the Grip Data chart for grip numbers.

Small Diameter BobTail Pin (4,8 to 9,5mm)

BT (HEAD STYLE) - (MATERIAL) (DIAMETER) - (GRIP NUMBER) (FINISH)

Example: **BT-R6-4GA** is a BobTail LockBolt fastener, Round Head, Carbon Steel grade 5.8, 4.8mm (3/16") Diameter, Grip 4 (3,2 - 9,5 mm), Zinc Electroplate.

HeadStyle	Suffix	Material	Suffix	Diameter	Suffix	Finish	Suffix
Round	No Letter	Carbon Steel Grade 5.8	R	4,8 mm (3/16")	6	Zinc Electroplate	GA
Truss Head	98T	Carbon Steel Grade 8.8	BR	6,4 mm (1/4")	8		
				7,9 mm (5/16")	10		
				9,5 mm (3/8")	12		

Other Headstyles and materials available on request

Large Diameter Imperial BobTail Pin (12.7 to 25.4mm)

BT (HEAD STYLE) - (MATERIAL) (DIAMETER) - (GRIP NUMBER) (FINISH)

Example: **BTR-BR16-4GA** is a BobTail LockBolt fastener, Round Head, Carbon Steel grade 8.8, 12.7mm (1/2") Diameter, Grip 4 (6,4 - 15,7 mm), Zinc Electroplate.

HeadStyle	Suffix	Material	Suffix	Diameter	Suffix	Finish	Suffix
Round	R	BR	Carbon Steel Grade 8.8	12,7mm (1/2")	16	Zinc Electroplate	GA
				15,9mm (5/8")	20		
				19,1mm (3/4")	24		
				22,2mm (7/8")	28		
				25,4mm (1")	32		

Other Headstyles and materials available on request

Small Diameter BobTail Collar (4,8 to 9,5mm) & Large Diameter Imperial BobTail Collar (12,7 to 25,4mm)

BTC (MATERIAL STRENGTH) - (MATERIAL) (DIAMETER) (FINISH)

Example: **BTC-R6GAH** is a Standard BobTail Collar, Low Carbon Steel, 4.8mm Diameter, Zinc Electroplate.

Material Strength Grade	Suffix	Material	Suffix	Diameter	Suffix	Finish	Suffix
Low Carbon Steel	No Number	Carbon Steel	R	4,8 mm (3/16")	6	Zinc Electroplate	GAH
Low Carbon Steel	5			6,4 mm (1/4")	8		
				7,9 mm (5/16")	10		
				9,5 mm (3/8")	12		
				12,7mm (1/2")	16	Zinc + Black*	BL*
				15,9mm (5/8")	20		
				19,1mm (3/4")	24		
				22,2mm (7/8")	28		
				25,4mm (1")	32		

Other collar types and materials available on request. Use suffix 5 collars to match with 8.8 grade pins

* For 12.7mm collar stand finish is GAT (Zinc Electroplate)

Large Diameter Metric BobTail Pin (12 to 20mm)

MBT (HEAD STYLE) - (MATERIAL) (DIAMETER) - (GRIP NUMBER) (FINISH)

Example: **MBT-DT12-10G** is a BobTail LockBolt fastener, Flanged Head, Carbon Steel grade 10.9, 12mm Diameter, Grip 10 (5 - 15mm), Mechanical Zinc.

HeadStyle	Suffix	Material	Suffix	Diameter	Suffix	Finish	Suffix
Flanged	No Letter	Carbon Steel Grade 10.9	DT	12mm	12	Mechanical Zinc	G
				14mm	14		
				16mm	16		
				20mm	20		

Large Diameter Metric BobTail Collar (12 to 20mm)

MBTC - (MATERIAL) (DIAMETER) (FINISH)

Example: **MBTC-R16BL** is a Standard BobTail Collar, Low Carbon Steel, 16mm Diameter, Zinc + Black.

Material	Suffix	Diameter	Suffix	Finish	Suffix
Low Carbon Steel	R	12mm	12	Zinc + Black	BL
		14mm	14		
		16mm	16		
		20mm	20		

Other collar types and materials available on request

Huck Tooling Systems

There are many different types of installation systems for the BobTail, dependent of fastener diameter, application type and application access. Some of the most popular tools are shown below but this is just part of our BobTail tooling range. Discuss your requirements with our **dedicated systems team** to find the optimum solution to suit your need.

To install BobTail the basic tooling requirement is:

Installation Tool – Either pneumatic or hydraulic

Nose Assembly – To match with the fastener and tool

Powerig® – To supply power to hydraulic tools

Additional Hose Set – Sometimes required to connect hydraulic tools to the Powerig

H Hydraulic

P Pneumatic

244BT/256BT **P**



Diameters:
244BT (4,8 - 6,4),
256BT (7,9 - 9,5)

The 244BT & 256BT Pneumatic Tools are specifically designed for rapid installation of BobTail.

2480L **H**



Diameters: 4,8 - 6,4

Hydraulic compact installation tool; high speed & high durability. Ideal for high volume production to install BobTail as well as other small diameter Lockbolts and structural blind rivets.

2503 **H**



Diameters: 7,9 - 9,5

Hydraulic installation with extra long stroke. Ideal for installing BobTail. Will also install other Lockbolts & structural blind rivets.

2620-PT/2620 **H**



Diameters: 12 - 12,7

Hydraulic installation tool, Installs BobTail as well as other 12 & 12,7mm Lockbolts and the BOM® blind fastener.

2628 **H**



Diameters: 12,7 - 15,9 - 16 - 19,1

Hydraulic installation tool. Installs BobTail, other large diameter Lockbolts and BOM® structural blind rivets.

BTT Series **H**



Diameters: 12 - 14 - 16 - 20 - 12,7
15, 9 - 19,1 - 22,2 - 25,4

The compact inline design of the BTT tools is configured for where reduced centre edge distance is required.

Swageforward® Tooling Series **H**



Diameters: 9, 5 - 12
12, 7 - 14 - 15,9 - 16
19,1 - 20 - 22,2 - 25,4

Hydraulic tooling. Ideal for use when application space is limited. Installs 9,5mm and 12 - 25,4mm Bobtail Lockbolts.

9.5 mm tool shown

HK432BT Powerig



Powerig; 3 phase electric, portable design. Can be used with all hydraulic installation tools except Huck-Spin.

BobTail Removal



A quick change of nose assembly from the installation nose to the cutter nose enables removal of BobTail fasteners using the same tooling system. BobTail cutter nose assemblies available in sizes: 6, 4 - 9,5 - 12 - 12,7 - 14 - 15, 9 - 16, -19,1 - 20 - 22,2 - 25,4mm

Aftermarket Solution

The BobTail can be installed outside the factory environment utilising the following:

- **Required nose assembly and collar cutter**
- **BTT35LS** – BobTail Tool
- **Additional hose sets**

To provide hydraulic power:

- **HP690** – Hand Pump or **911D** - Hydraulic Diesel Powerig



Installation Gauges



Easy to use ring gauge used to ensure each installation is correct.

For specific information on BobTail tooling visit the BobTail page at www.afshuck.net

How It Works

How BobTail Works

Clamp Force or Pre-Load: In the initial stages of the installation process, the tool engages and pulls on the tail of the fastener. The joint is pulled together before the anvil portion of the nose assembly is forced down the collar. This progressively locks (swages) it into the grooves of the harder pin. The pin and swaged collar combine to form the installed fastener.

The squeezing action reduces the diameter of the collar, increasing its length. This in turn stretches the pin, generating a clamp force over the joint.

Shear strength of BobTail fasteners vary according to the material strength and minimal diameter of the fastener. By increasing the diameter or the grade of material, the shear strength of the fastener can be increased.

The tensile strength of BobTail fasteners is dependent on the shear resistance of the collar material and the number of grooves it fills.

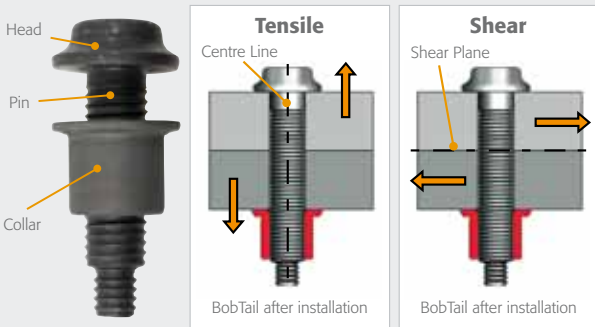

Installation Sequence

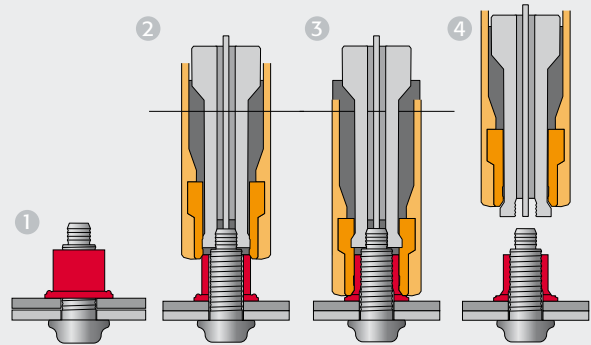

- 1 • Pin placed into prepared hole
• Collar placed over pin
- 2 • Tool is placed onto the annular pull grooves and activated
• A puller in the nose assembly draws the pin into the tool
• Pin head pulled against material
• Anvil pushes collar against joint
• Initial clamp generated
- 3 • Tool swages collar, increasing clamp
- 4 • Swaging of the collar into the pin lockgrooves is complete, tool ejects the fastener and releases the puller, installation complete

Contact

Alcoa Fastening Systems
Telford Operations,
Unit C, Stafford Park 7
Telford
TF3 3BQ
England
Tel : +44 (0) 1952 290011
Fax : +44 (0) 1952 204670
Email : info@huckfasteners.net
Web : www.afshuck.net

Alcoa Fastening Systems
Kelkheim Operations,
Industriestr. 6
65779 Kelkheim
Germany
Tel : +49 (0) 6195-805-0
Fax : +49 (0) 6195-2001

Alcoa Fastening Systems
St Cosme Operations,
9 rue de Cressonnieres
72110 Saint Cosme en Varais
France
Tel : +33 (0) 2.43.31.41.00
Fax : +33 (0) 2.43.31.41.41



TS 504575-000
FM 80437



EMS 60542

Disclaimer:

The information contained in this publication is only for general guidance with regard to properties of the products shown and/or the means for selecting such products, and is not intended to create any warranty, express, implied, or statutory; all warranties are contained only in AFS's written quotations, acknowledgments, and/or purchase orders. It is recommended that the user secure specific, up-to-date data and information regarding each application and/or use of such products.

AFS HB01 0811

© 2011 Alcoa Fastening Systems. All rights reserved.

www.afshuck.net | info@huckfasteners.net

**Alcoa
Fastening
Systems**

